

### 48" DIA COMPONENTS

SIZE (ID)	HEIGHT (ID)	WEIGHT
BASE	48"	4,983#
RISER	24"	1,733#
RISER	36"	2,600#
RISER	48"	3,371#
RISER	CUSTOM	866#/VF
CONE	24"	1,656#
CONE	30"	2,077#
CONE	36"	2,579#
TOP SLAB	10"	1,292#

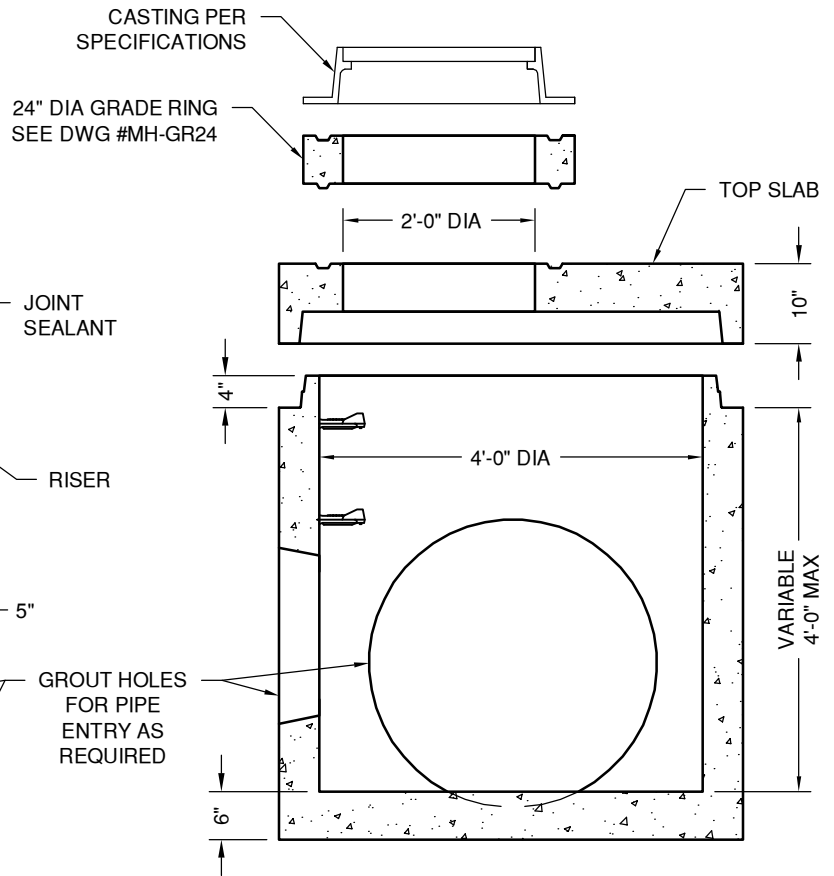
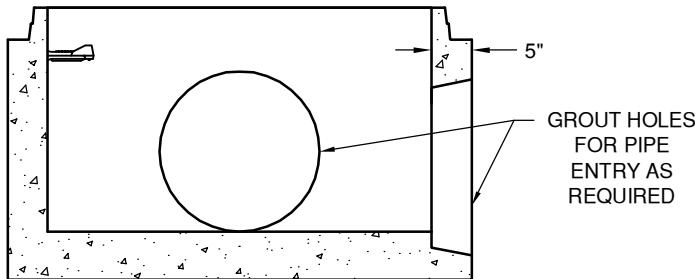
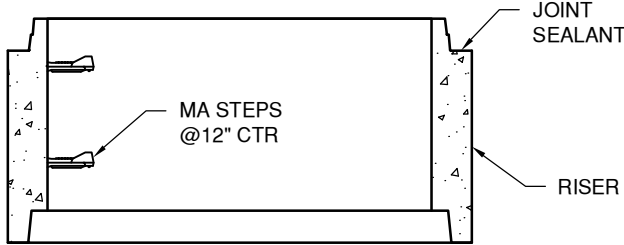
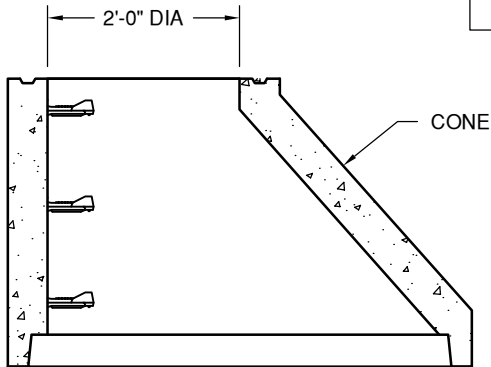
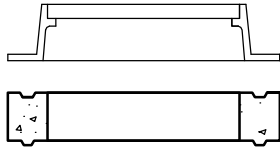

#### CONE TOP SECTION VIEW

**MAX PIPE SIZE**  
 30" HDPE/24" RCP > 120°-180°  
 24" HDPE/21" RCP > 90°-180°

#### FLAT TOP SECTION VIEW



"NPCA" CERTIFIED PLANT  
 16700 SIMA GRAY RD, HENRYVILLE, IN 47126  
 Phone: (812) 246-6258 Fax: (812) 294-4862

#### SPECIFICATIONS

CONCRETE: 4500 PSI @ 28 DAYS  
 REINFORCEMENT: ASTM A-615, GR 60  
 DESIGN LOAD: AASHTO HS-20  
 DESIGN SPECIFICATION: ASTM C-478

WEIGHT: See Chart

### STORM MANHOLE 48" DIAMETER

DATE: 12-19-16

DWG #STM-MH-48