

48" DIA COMPONENTS		
SIZE (ID)	HEIGHT (ID)	WEIGHT
BASE w/INVERT	24"	4,538#
RISER	24"	1,733#
RISER	36"	2,600#
RISER	48"	3,371#
RISER	CUSTOM	866#/VF
CONE	24"	1,656#
CONE	30"	2,077#
CONE	36"	2,579#
TOP SLAB	10"	1,292#

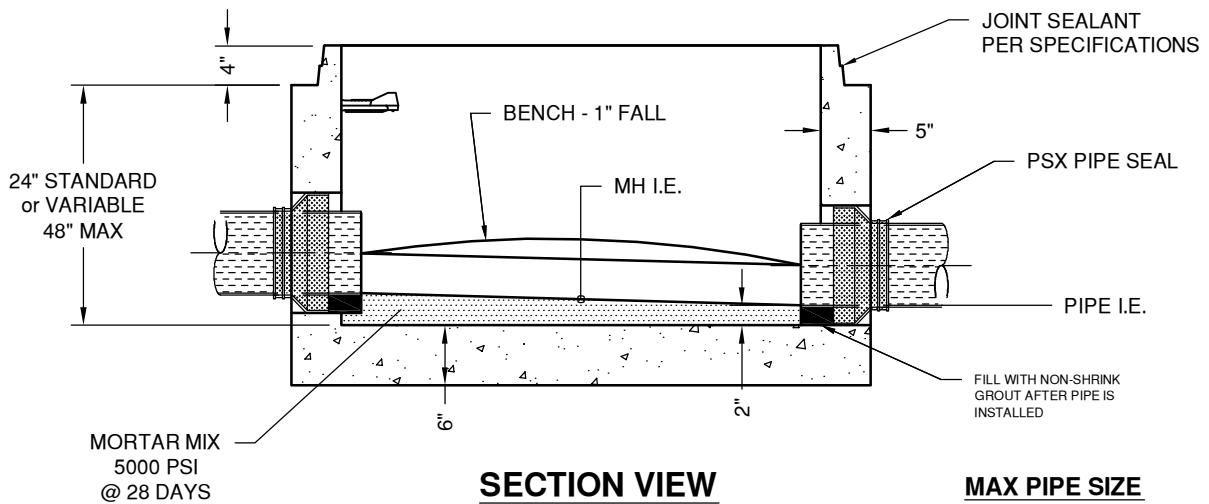
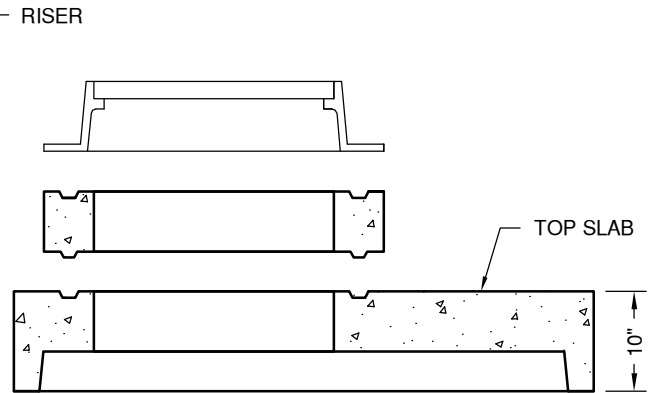

"NPCA" CERTIFIED PLANT  
16700 SIMA GRAY RD, HENRYVILLE, IN 47126  
Phone: (812) 246-6258 Fax: (812) 294-4862

**SPECIFICATIONS**

CONCRETE: 4500 PSI @ 28 DAYS  
REINFORCEMENT: ASTM A-615, GR 60  
DESIGN LOAD: AASHTO HS-20  
DESIGN SPECIFICATION: ASTM C-478

WEIGHT: See Chart

**SANITARY MANHOLE  
48" DIAMETER**

DATE: 12-21-16

DWG #SAN-MH-48